

Floorplan Design

Size: EthoSource can provide workstations in many different sizes depending on your specific needs. Essentially we provide any size workstation within 6" increments. Typical workstation sizes range from 6'x6' up to 10'x10' and anything in between. Certain applications may require smaller stations (such as telemarketing or "touchdown" stations) or larger stations may be called for if you are trying to create the space and feel of a large office.

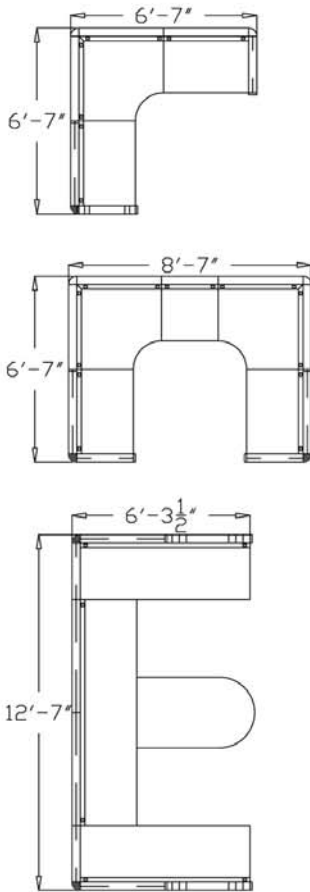

Height: Our workstations can be customized with various height partitions to create exactly the openness or privacy that is required. Creative use of differing heights in a workstation environment is a great way to provide an interesting landscape that addresses multiple needs simultaneously. Heights can vary within the same workstation. The chart below indicates the various height options that are available to you as well as a general description and benefit of using each height in your office space.

HEIGHT	DESCRIPTION	BENEFIT
38"	No privacy- Maximum Openness	This height allows for full interaction between co-workers and maximum visibility around the office. Often used in front of windows.
54"	Seated Privacy	This height allows for an open feel within the office while still allowing for privacy when sitting. 54" high can accommodate some overhead and tile storage.
70"	Full Privacy	This height offers full visual privacy within the office and can also accommodate all types of overhead and tile storage.
86"	Private Office Feel	This height is typically used when creating the feel of a private office. Doors can be added to this height.



Layout: The way that workstations are arranged in a space is typically dictated by the space itself or how the occupants of the space need to interact and work with each other. Often, workstations are organized into clusters that share a center spine. This tends to be the most efficient in terms of space and cost. However, each floorplan is unique and our professional designers will help present options that meet your business requirements.

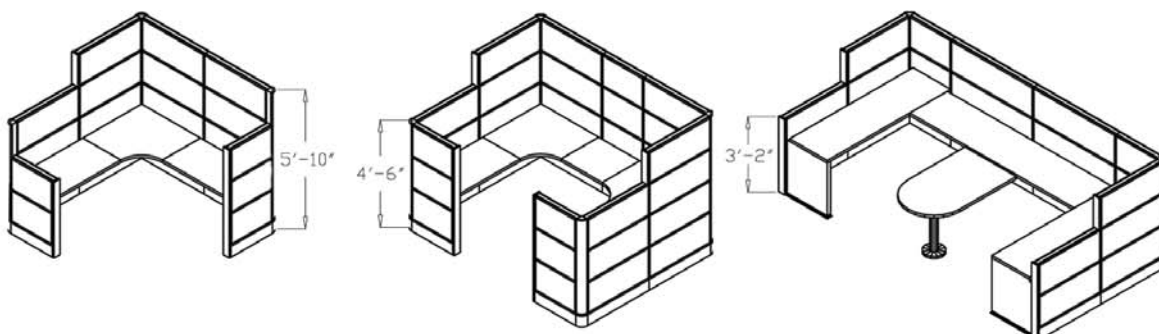

Adding Storage

EthoSource offers numerous storage options with our workstations. Storage can be added at any time, even after the installation. Below are the 3 main categories of storage to consider while customizing your workstation.

Overhead Storage:

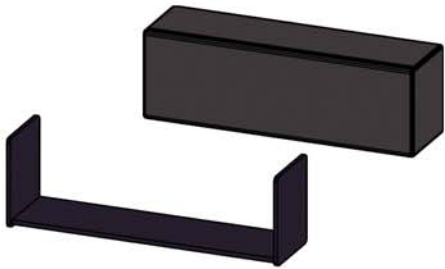

Overhead storage options include closed flipper door units as well as open shelves. This type of storage is particularly useful for items such as binders, catalogs, manuals, etc. The closed flipper door units are lockable and can have a fabric or laminate door front to coordinate with or accent the rest of the workstation.

Under Surface Storage:



Under worksurface storage options include pedestals, lateral files, pencil drawers, and open shelving. Typically, under surface storage is utilized for filing (either letter or legal) or for storage of general office items.

Rail Tile Storage:

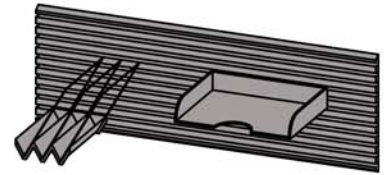

Rail tiles are utilized along with paper management accessories to allow for the organization of and quick access to current work in progress. The rail tile becomes an integral part of your workstation, allowing a wide selection of paper management accessories that include: paper trays, diagonal trays, organizer trays, vertical bins, triple arches, and mini shelves among others. These accessories are easily repositionable items that enhance worker efficiency and organization.



[Click Here To See Our Current Inventory of Pre-Owned Filing](#)

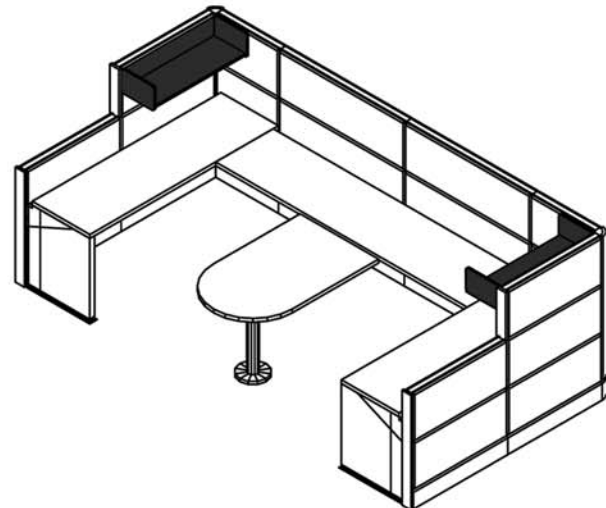
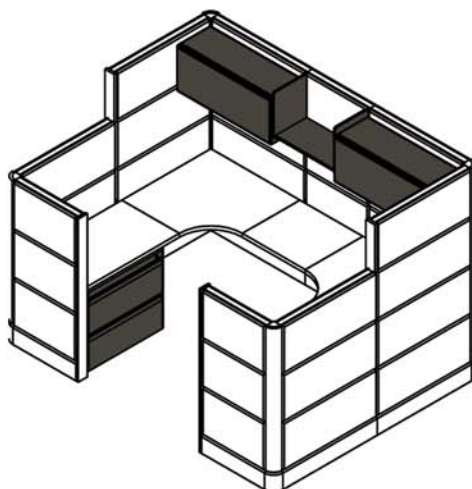
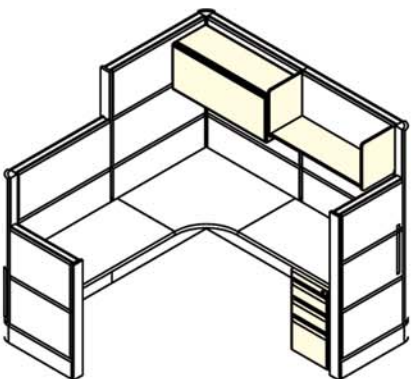

Choosing Your Tiles...

Herman Miller Ethospace offers workstation flexibility and adaptability that is unmatched in the furniture industry. From its unlimited number of design options, to its capacity for data and telecommunications, to the ease of future reconfigurations, Ethospace can meet even the most demanding functional and aesthetic requirements. With structural steel frames at the core, “tiles” are hung to create and define the perfect workspace. Listed below are images and descriptions of various tile types we can use in the design.

Tile Type	Finish Options	Application
 <p>Fabric</p>	Fabric Covered. As-is fabric or NEW fabric of customer’s choice can be utilized.	Primary tile used in the workstation. Gives the overall “look” of the station.
 <p>Accent</p>	Fabric Covered. As-is fabric or NEW fabric of customer’s choice can be utilized.	Accent tiles are simply face tiles that are in a different or complementary fabric to create an interesting aesthetic accent.
 <p>Acoustic</p>	Fabric Covered. As-is fabric or NEW fabric of customer’s choice can be utilized.	This tile should be utilized in areas where sound is of particular concern.
 <p>Tackable</p>	Fabric Covered. As-is fabric or NEW fabric of customer’s choice can be utilized.	This tile can be used to improve organization with a tackable interior vertical surface.
 <p>Painted</p>	This metal tile can be painted any of EthoSource’s standard paint colors.	Painted tiles provide a clean look and are often used to accent fabric tiles.
 <p>Laminate</p>	This is a tile that is made NEW in the standard laminate of the customer’s choice.	Often made of wood laminate and used on the exterior of the station to create an up-scale appearance.
 <p>Window</p>	Window tiles come in various frame colors and either clear, translucent, or dot pattern glass.	Used to allow visual access to natural light and other areas in the office. They are aesthetically appealing and create an open feel.
 <p>Marker</p>	Marker tiles come in standard whiteboard white and a black frame.	Marker tiles are dry erase boards that snap in and become a part of your Ethospace station.
 <p>Rail</p>	Rail tiles are metal and can be painted any of EthoSource’s standard paint colors.	Rail tiles accommodate the hanging of paper management tools with your workstation.

Click below to see some fabric choices:



Digital Fabric Card



Burch

GUILFORD
OF MAINE



Green Fabric Card

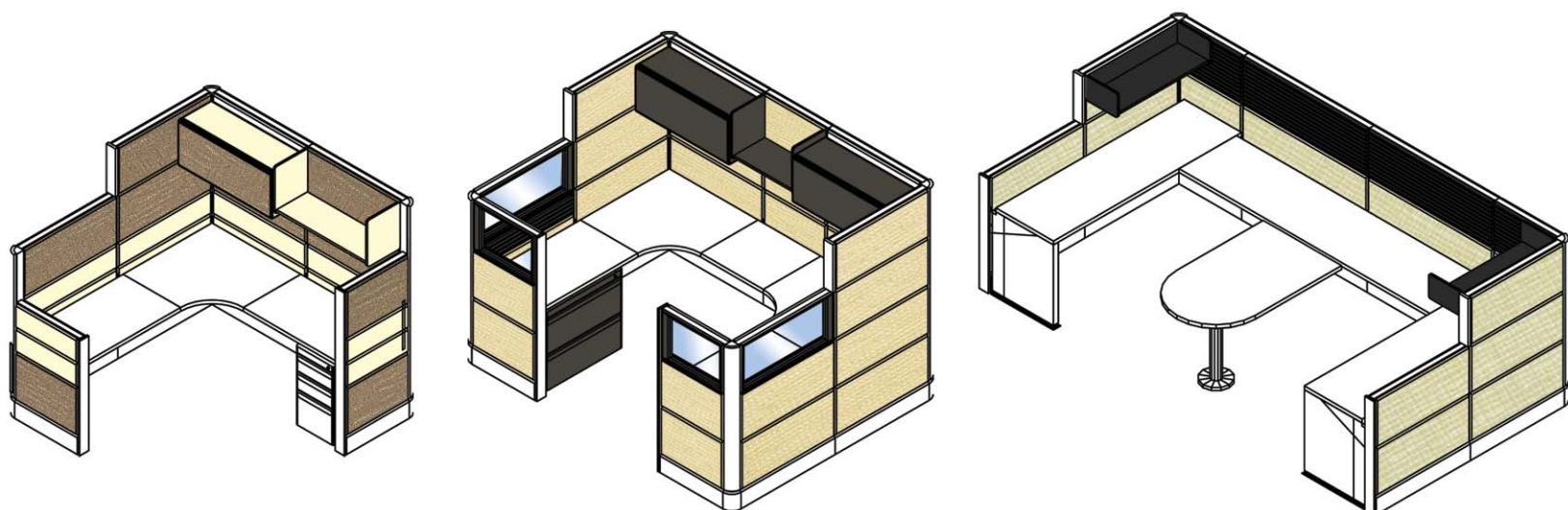

Finish Options

Fabrics: You can use any of the countless number of fabric choices to add color and define the style of your workspace. Solids and patterns from leading manufactures like Burch, True Textile (Guilford), CF Stinson, and Mayer can be used to help create the look and feel you want. For those interested in being green, a growing number of 100% recycled fabrics are available.



Finishes: A wide array of laminates are available, not only for the horizontal worksurfaces, but also for vertical surfaces like tiles and flipper doors. Solids, patterns, and woodgrain laminates from major manufacturers like Wilsonart, Pionite, Formica and Nevamar are available to help you achieve your design goals.



Paint/Trim Colors: Ethosource offers a number of paint colors to compliment your fabric and laminate selections as well as any of your other interior finishes.

Available paint colors are as follows:



Questions about how to balance look, feel and functionality?
Our professional design team is here to help you pull it all together.

